

Air Research Technology Inc.

WingExtension and Spar Reinforcement Installation Guide #18025
For Cessna 180, 182 and 185 models modified in accordance with
Transport Canada STC SA 93-136 and FAA STC SA00276NY.

Issue # 1 December 15, 2011

Qualified aviation maintenance personnel must perform the procedures
documented herein. All workmanship must be in accordance with
FAA AC 43.13-1B.

This document supplements drawings
R-1582-180-182-185 and SB1-96

REVISION AND DISTRIBUTION

When this document requires revision it will be reissued in whole and the issue
number will be increased. Air Research Technology Inc. provides copies of this
document with its installation kits. This document is also available on line at:

<http://www.wingxstol.com/html/faq.html>

For technical assistance please contact:

Air Research Technology Inc.
3440 McCarthy St.
Montreal, QC
Canada H4K 2P5

(888) 325 2588 ph
(514) 337 7588 ph
(514) 337 3293 fax
www.wingxstol.com

TABLE OF CONTENTS

TOOLS REQUIRED.....4

IMPORTANT NOTE ABOUT THE JIG SET RIVET4

Part I – INSTALLING THE WingExtension4

 Wing tip lighting and other electrical connections4

 Preparing the wing for fitting.....4

 Preparing the WingExtension5

 Preliminary fitting and alignment.....5

 Dihedral alignment along the FWD and AFT spar.....6

 Leading edge alignment (sweep back)6

 Marking position of the skirt6

 Transfer drill holes onto the skirt strap.....7

 Positioning and installation of the MS21061L08 nut plates.....8

 The aileron cutout.....8

 Trimming the trailing edge8

 The trailing edge stiffener p/n 1582-79

 Completing the installation.....9

 Positioning of the forward nut plates in the nose rib.....9

 Various STOL kit leading edge devices require optional “BUSHTON CUFF” p/n 1582A-1010

Part II - INSTALLING THE WING SPAR REINFORCEMENTS.....11

 Wing spar reinforcement Installation.....11

 Inspection cover assembly p/n 1582A-1111

 Preparing the area for the reinforcement straps.....11

 Installing the packer p/n 2024T3 (24 X 1.5 X 0.125).....12

 Installing the doubler p/n 2024T3 (18 X 1.1875 X 0.125).....12

Part III – INSPECTION FOR PRESENCE OF MAIN SPAR ANGLE STIFFENER14

Part IV – INSTALLATION OF STAINLESS STEEL STRAP.....15

PART V - PLACARDS, DOCUMENTATION FORMS AND REPORTS17

PART VI - W & B INFORMATION.....18

PART VII – AIRSPEED INDICATOR RANGE MARKING.....18

Figures19

 Figure 1: Spar Construction Detail.....19

Air Research Technology Inc.
WingExtension and Spar Reinforcement Installation Guide #18025
Issue # 1 , December 15, 2011

Figure 2: Spar Section Detail With Angle Stiffener Present	20
Figure 3: Spar Section Detail Without Angle Stiffener Present	20
Figure 4: Positioning of Stainless Steel Strap Between Rivets	21
Figure 5: Positioning Anchor Nuts and Splicing Stringers.....	22
Figure 6: Leading Edge alignment on pre-1973 wings	23
Figure 7: Access Hole Installation.....	24
Figure 8: Placards	25

TOOLS REQUIRED

2 metal straight edges approx.72" or 50' feet of fine string.

Hole finder or transfer tool (optional)

Standard sheet metal tooling including clecos.

Countersink bit (100 °) and drill bits.

Standard riveting equipment.

Metal clamping tools (2 or 3)

All parts and hardware required for a complete installation are included with your kit. The materials supplied are listed on the shipping checklist included with your *Wing Extensions* documentation.

IMPORTANT NOTE ABOUT THE JIG SET RIVET

Your *WingExtensions* have been assembled by the manufacturer in an assembly jig with one (1) jig set rivet 3/32" situated inboard which holds the trailing edge skins in place. It is not normally required to remove the JIG SET Rivet until step #10 , however on some aircraft it is necessary to remove this rivet in the early stages of the installation procedure in order to adjust more accurately the airfoil alignment and washout.

Part I – INSTALLING THE *WingExtension*

1) Wing tip lighting and other electrical connections

- Remove the plastic wing tip and disconnect the wires to the navigation and strobe lights.
- If applicable, remove strobe light power supply and attachment bracket from rib.
- Extend existing wiring, use supplied wire #M22759/ 16-18-9 and connectors #320559

2) Preparing the wing for fitting

- Remove the plastic wing tip and check the existing wing to make sure there is no top or bottom skin overlapping past the wing rib at wing station 208.00. If necessary cut away or file away all excess aluminum until top and bottom wing skins are flush with the outboard edge of the existing center rib at wing station 208.00 .
- The supplied MS21061L08 anchor nuts are used to secure your *WingExtension* onto the wing. It is important that they be installed at strong points and positioned through the spar and or stringers as indicated in figure 5 in this guide or in Detail " A" of Drawing # R1582-180-182-185
- For future positioning of the anchor nut plates (step #9), drill out existing rivets at end of each stringer or spar.
- On most aircraft, the stringers of the existing wing butt up against or overlap the rib cap, however, this is not always the case, therefore if

Air Research Technology Inc.

WingExtension and Spar Reinforcement Installation Guide #18025

Issue # 1 , December 15, 2011

required, splice the stringer to make it longer as indicated in Detail "A" refer to splicing methods and technique as depicted in the Cessna Service Manual for series 100 aircraft.

- A clean, flush surface is required to allow for a tight fitting of the *WingExtension* skirt onto the wing. Therefore, remove all "brazier or universal head rivets" found along the outboard two (2) inches of the wing extremity, replace these fasteners with flush head rivets.

3) Preparing the *WingExtension*

- On all early model Cessnas built prior to 1973, LEFT AND RIGHT *WingExtensions* look identical but they should not be interchanged. A serial numbered decal is affixed to the center rib section of each *WingExtension* and identifies LEFT (LH) or RIGHT (RH).
- Remove plastic wing tip and place it on workbench. Fit the plastic wing tip over the wing- extension. In order to fit the *WingExtension* into the plastic wing tip, trim away excess metal at the outboard trailing edge corner of the *WingExtension* . A tight fit is desirable. Do not trim too much.
- With the wing tip fitted firmly in position, mark a small line at top and bottom of *WingExtension* skin to coincide with the inboard trailing edge of the plastic wing tip. This line will be used later in step #11 when trimming the trailing edge.
- Remove the plastic wing tip from the *WingExtension*. Final installation of the plastic tip will be in step 14.

4) Preliminary fitting and alignment

NOTE

Every wing is slightly different and will require some on sight adjustment in order to ensure correct alignment in all geometric planes. So as not to permanently damage your new kit, we suggest the use of speed tape to temporarily fix each extension in position then step back a certain distance and take time to view the results from the front, back and side. Make all adjustments at this time before beginning to cut, drill and fasten . Fit the *WingExtension* over the existing wing extremity. Seat the leading edge of the extension firmly against the wing leading edge contour and apply pressure in order to push the assembly inboard as much as possible. You may have to repeat parts of step #2 again in order to assure a flush fitting. The inboard trailing edge of the *WingExtension* assembly will temporarily envelope the outboard section of the ailerons, this is normal , the overlap will be marked for cutout at a later time (see "cut out" step#10).

5) Dihedral alignment along the FWD and AFT spar.

(Use 2 or 4 straight edges or 50' string if desired)

Using the rivet rows of the main spar on the top and bottom of the wing as a guide take a straight edge (min.72") and firmly set it or using duct tape, tape it in line along the top/bottom spar rivets, extended it from station 154.00 all the way out to the extremity of the *WingExtension*. It is preferable to use 2 straight edges or to alternate by positioning the straight edge over and under the wing as required. Hold the Extension firmly in place, then raise and lower it so as to achieve an even gap along the straight edge on the top & bottom side of the wing. An even gap should insure proper dihedral alignment. Repeat step #5 along secondary / auxiliary "aft. spar" to insure alignment of the aft portion of the *WingExtension* airfoil. The secondary spar or aft. spar is sometimes called the false spar.

6) Leading edge alignment (sweep back)

Camber lift airfoil NACA 2412 (post 1973)

The leading edge of this airfoil design sweeps back in a straight line from wing station 100.00 all the way out to the tip. Use a straight edge (min. 72" long) to align the leading edge of the extension with the leading edge of the wing . Optionally you can tape a string along the L/E extending from just past the strut at wing station 101.00 to the end of the extension at wing station 226.00. Use spacers to clear the thickness of the skirt strap, and align the *WingExtension* leading edge accordingly.

Symmetrical airfoil NACA 0012 (pre 1973)

On all wings built before 1973, the leading edge sweeps back a discernible amount at wing station 190 to 208 . DO NOT USE this section for alignment of the *WingExtension* leading edge. We suggest to extend a straight edge or string from wing station 101.00 to 226.00 , measure the gap between the leading edge and the straight edge at 208.00 and maintain this gap along the entire leading edge of the *WingExtension* ideally within $\pm \frac{1}{4}$ inch. (see fig.6)

7) Marking position of the skirt

With *WingExtension* perfectly aligned and held in position, draw a line around the wing surface, this will indicate the position of the *WingExtension* skirt around the wing.

8) Transfer drill holes onto the skirt strap

CAUTION

When positioning the holes for the securing screws be sure to maintain 3/8" minimum edge distance along the skirt strap at all times.

- Before drilling the skirt strap, fix the *WingExtension* in place at the leading edge. You should pull it back tightly and use speed tape to secure the extension temporarily in place, or, if you wish, use the original wing tip screw holes found in the wing at this position, there should be one on the top L/E and one on the bottom L/E. Use these screws to secure the *WingExtension* in place. This will assure a tight fit around the contour of the leading edge cuff prior to positioning of the anchoring holes.
- With *WingExtension* held firmly in place at the leading edge, use a straight edge or ruler lined up along the existing row of rivets of each stringer, front spar and rear auxiliary spar. Using these rows of rivets as a guide draw a series of lines onto the skirt strap, and mark the skirt strap for drilling. You can also use a hole finder or any other suitable method to accurately position the anchoring holes onto the skirt strap.
- Start drilling your anchor nut holes while moving from the front (leading edge) then bottom leading edge and alternate from Top to Bottom of the skirt , going towards the trailing edge and making sure that the skirt is fit tight around the wing. Use a #40 drill bit and drill through the skirt at the marked locations, remember to install a cleco into each drill hole to insure no movement or misalignment of the *WingExtension*.
- Verify final alignment of the *WingExtension* for dihedral, sweep back and wash out. Minor adjustments can be made by removing the appropriate clecos and redrilling with a #30 drill bit while holding the *WingExtension* in the correct position. Removal of the JIG SET RIVET may be required at this time in order to avoid possible warping of the top and bottom skins.
- Finish with a #20 drill bit and enlarge the drill holes for anchor nuts.
- Remove the *WingExtension* before proceeding to the next step.

9) Positioning and installation of the MS21061L08 nut plates

NOTE

Every wing is different and will require some on site adjustment to insure that the anchor nuts are positioned accurately. The anchor nuts are used to hold your *WingExtension* in place and must be installed at strong points such as through the spar and stringers. Maintain a minimum edge distance of 3/8 inches along the *WingExtension* skirt.

- In some cases the existing wing stringers are not always butted against the center rib at wing station 208.00 . If necessary extend the stringer(s) by adding a 6" inch splice use a minimum of (4) AD3 rivets to fasten the splice. The stringer extension can be positioned in such a way as to butt up against or overlap the center rib cap, both methods are approved (Refer to Detail " A" of Drawing # R-1582-170-172-175 or figure 5.
- Insure anchor nut rivets are in line as much as possible and do not interfere with existing rivets along the spar or stringers.
- Use of following supplied rivets is approved to fasten the nut plates along the top and bottom of the wing: Solid rivet MS20426AD3-3 & AD3-5 , Pull-Thru rivet MS20605AD3W4 or CR9116-3-4. Because the nut plate rivet is non-structural use of pop rivet 3/32" A34A is also approved.
- Install the *WingExtension* to the wing using supplied machine screws (AN525-832R8).

10)The aileron cutout

- Gradually cutout the metal overlapping the aileron. BEWARE not to trim off too much material. The final result should give you a clearance of approximately 1/2" in. between the aileron and *WingExtension* inner edge this should coincide with the edge of the rib web.
- Carefully file or dress out the area to attain a smooth edge, if require remove the JIG SET RIVET.

11)Trimming the trailing edge

- Temporarily install the plastic wing tip. It may be necessary to trim the trailing edge outboard corner of the *WingExtension* with a file to permit a proper tight fit into the plastic wing tip.
- With the plastic wing tip fitted firmly in position, use a straight edge and mark a line on the top and bottom skins extending from the outboard trailing edge of the aileron to the trailing edge of the plastic wing tip. Refer to line scribed in step #3.
- Following the scribed line along the top and bottom skins of the *WingExtension* trailing edge, carefully cut off all the excess material.
- Remove the plastic wing tip.

12)The trailing edge stiffener p/n 1582-7

Two trailing edge stiffeners are provided in every kit. Insert the stiffener in between the *WingExtension* trailing edge skins. Adjust the stiffener by cutting to proper length then clamp the newly reinforced trailing edge skins together with the stiffener sandwiched in the middle.

NOTE

Watch for induced warping of the airfoil on the top and bottom skins of the *WingExtension*. This could be caused by misalignment of the trailing edge airfoil.

ADDRESS THIS PROBLEM BEFORE RIVETING STIFFENER INTO PLACE.

- When airfoil symmetry is assured, use clamps to tighten firmly along the trailing edge then drill & install 3/32" rivets through the skins and stiffener at 1-inch intervals along the trailing edge.
- The skin is thicker along the reinforced skirt strap, if necessary, install (3 to 5) additional rivets in the area of the skirt strap trailing edge.
- To attain a smooth finish along the trailing edge of the *WingExtension*, file clean all metal edges.

13)Completing the installation

If required, reinstall the strobe light power supply and bracket to the new end rib then connect the wires and test for proper function.

14)Positioning of the forward nut plates in the nose rib

Your *WingExtensions* do not have pre-drilled holes or anchor nuts installed in the top section of the leading edge nose rib. Securing your plastic wing tip in place will require on site fitting of the forward anchor nut(s) which are positioned along the top and bottom of each nose rib as required.

- Using your existing plastic wing tip as a guide, mark the top most forward screw holes onto your new *WingExtension*, then drill out and install the anchor or Tinnerman nut(s) as required. Some aircraft equipped with leading edge STOL kits may require 2 or more screws top and bottom in order to fasten the plastic wing tip securely in place.
- Once the hole(s) are positioned, fasten the anchor nuts with either Pull-Thru , pop-rivets or solid rivets, as this is non-structural all methods are approved. Use fasteners of the type and number supplied or use Tinnerman nut(s).
- When using Tinnerman nut(s), pre-drill the hole then remove the rivet binding the top leading edge skin to the nose rib and insert a Tinnerman as required.
- You can now install the original plastic wing tip onto the *WingExtension*.

15) Various STOL kit leading edge devices require optional “BUSHTON CUFF” p/n 1582A-10

As an option , you can order an enhancement cuff p/n 1582A-10 to fit over your new *WingExtension* leading edge and skirt strap. The optional “ BUSHTON CUFF” is STC approved and manufactured to closely match the existing leading edge airfoil design of the most popular STOL kits, this optional cuff is longer and wider than required therefore some refitting and trimming may be necessary.

- Insert the optional Bushton cuff under the existing leading edge device and it should take the shape of the existing STOL leading edge cuff .
- Some plastic wing tips are designed to have the L/E cuff inserted into the wing tip, if this is the case you can reinstall your plastic wingtip and use it as guide. Position the optional cuff enhancement into the tip thereby assuring a nice fit and the required shape should fall into place.
- If this method is not available to you. Follow the existing lines of contour and sweep back to match as much as possible the existing leading cuff shape.
- Trim the optional cuff to the desired size, paint and install using approved fasteners and in order to keep your wing extensions removable, remember to use machine screws where indicated.

The BUSHTON CUFF p/n 1582A-10

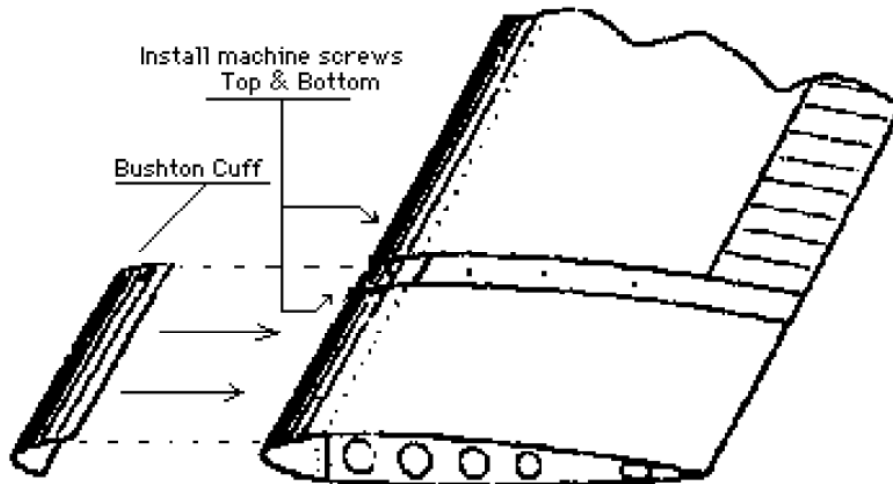

- 1) To install, follow contour of existing STOL kit leading edge and rivet along the same lines.
- 2) To allow for easy removal of *WingExtension*, install machine screws where indicated.

Part II - INSTALLING THE WING SPAR REINFORCEMENTS

16)Wing spar reinforcement Installation

- The latest revised drawings are supplied with each kit , always install the wing reinforcements using the most current drawings or contact the manufacturer for the latest issue. Refer to drawing R1582-180-182-185 and drawing SB 1-96
- Remove existing rivets along the upper spar cap extending approximately from wing station 125.00 to 160.00. You will be doubling the amount of rivets along this section of the upper spar cap. By adding one rivet between each existing rivet in order to obtain an approximate 1" inch pitch. These 5/32" rivets are supplied with your kit. Be sure to use correct fastener length, refer to the P/N # and dash number appropriate to the thickness of the wing station area to be riveted.

17)Inspection cover assembly p/n 1582A-11

Installation of additional inspection holes may be required on the underside of the wing in order to provide access for the bucking bar while riveting the doubler and packer straps into place. Four (4) Inspection cover assy's are supplied in each kit. Refer to Figure 7 for access hole installations.

CAUTION

Metal fatigue cracks may occur on high-time Cessna aircraft. They are normally found along the center rib ,channel and top skin situated along the upper spar cap extending from wing station 124.00 to 196.00. During the initial installation procedure, all deficiencies can be readily spotted when viewed through the newly installed inspection holes. In order to maintain the structural integrity of the wing assembly, any defects or cracks found in the wing assembly must be repaired immediately. Suitable repair procedures can be found by referencing Section 17 of the appropriate Cessna Service Manual.

18)Preparing the area for the reinforcement straps

- The packer and doubler straps are each 0.125 " thick, their combined thickness at the splice point near the center rib at wing station 136.00 is 0.250" In order to allow passage and positioning of the straps along the upper spar cap , cut out a small portion of the top forward center rib at station 136.00 and station 154.00. The center rib at wing station 154.00 requires the passage of one strap only (0.125") and will not require as much notching as the inboard rib. See drawing for detailed view.
- Use a Dremmel tool or other type high speed rotary cutter to provide a minimum cut-away through the center ribs at wing station 136.00 and

154.00 just below the spar angle then file all surfaces to a smooth finish.

19)Installing the packer p/n 2024T3 (24 X 1.5 X 0.125)

Once the cut outs of the center ribs are complete, the packer should be placed along the upper spar cap. and butted up against the bulb plate at wing station 136.00. This is the splice point selected for reinforcement. Place the tapered end of the packer outboard and extend it through the newly completed center rib cutout at 154.00. The packer should extend all the way out to wing station 160.00. Caution, do not place packer tightly against the bulb plate at the splice point (wing station 136.00) , a minimum end gap of 0.032" is recommended .

20)Installing the doubler p/n 2024T3 (18 X 1.1875 X 0.125)

The shorter reinforcement strap called the doubler is tapered at both ends and should be placed behind the bulb plate and over the splice at wing station (136.00) as depicted in the drawing. Center the 18" doubler strap at the splice area at wing station 136.00 . When both straps are in place fasten all using 5/32" rivets MS20426AD5-11 at 1" pitch from wing station 127.00 to 145.00 approx. Then use 5/32" rivets MS20426AD5-9 at 1" pitch from wing station 145.00 approx. to the end of the reinforcing straps at approx. wing station 160.00.

THIS PAGE LEFT BLANK

Part III – INSPECTION FOR PRESENCE OF MAIN SPAR ANGLE STIFFENER

- 1) Inspect the area along the lower main spar cap from Station 90 outboard to Station 110, and determine if the factory angle stiffener is present.
- 2) Both wings, left and right must be inspected individually.
- 3) Open the inspection hole situated on the underside of the wing, aft of the spar, closest to where the strut connects to the wing. Using a flashlight and a mirror, by visual inspection, ascertain if the subject wing has the “angle stiffener” installed along the lower spar cap between Wing Station 90 and 110 (approximately). Refer to Figures 1 and 2 and 3 to assist identification of the “angle stiffener”.
- 4) If the “angle stiffener ” is present, no further action is required.
- 5) The installation of the Stainless Steel Strap in accordance with Part IV is MANDATORY on all wings that do not incorporate the factory installed “angle stiffener”.

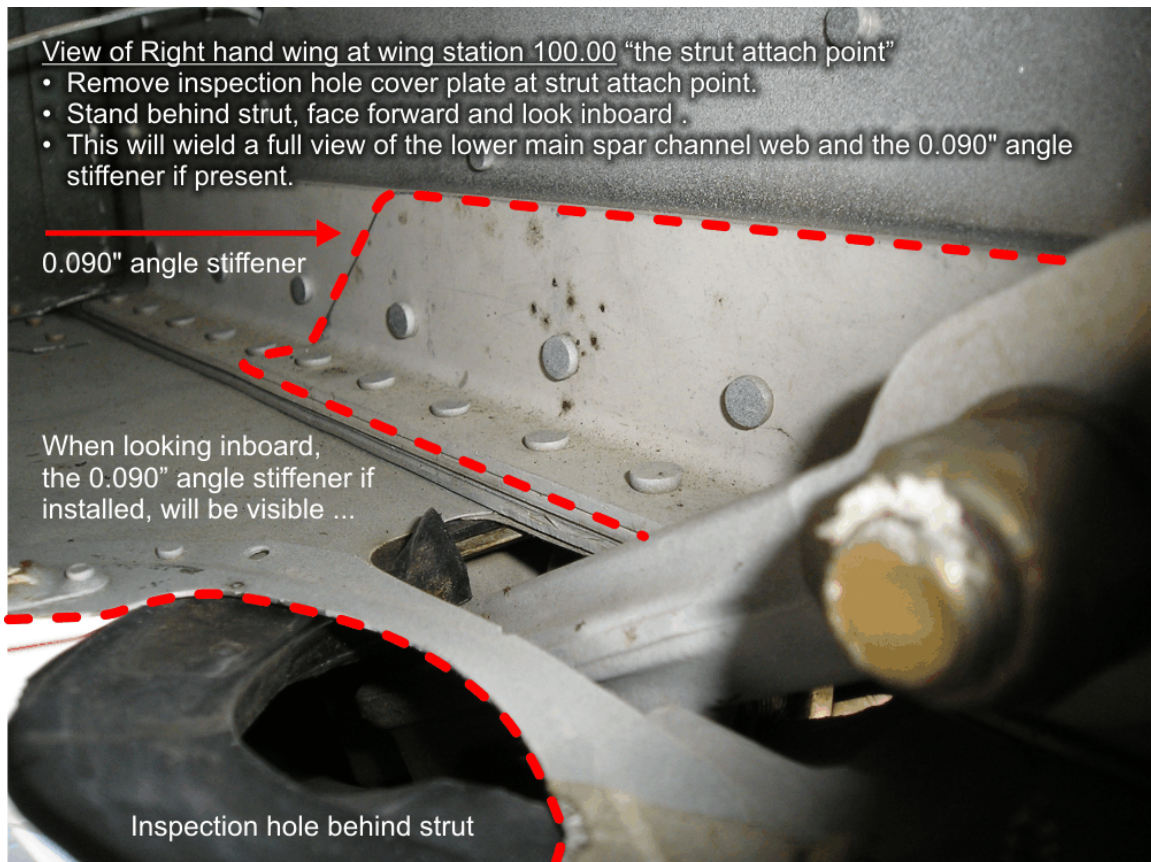

Part IV – INSTALLATION OF STAINLESS STEEL STRAP

CAUTION

Each wing must be inspected individually. Stainless steel straps must be installed on wings without “angle stiffeners”. In such wings, correct installation of the stainless steel strap is critical to maintain structural integrity of the wing. Qualified aviation maintenance personnel in accordance with the procedures below must perform this installation.

All workmanship must be in accordance with FAA AC 43.13-1B.

WARNING

DO NOT INSTALL the Stainless Steel Strap if the “angle stiffener” is present. Structural integrity will be compromised if the installer attempts to install the stainless steel strap in combination with an “angle stiffener”.

NOTE

If “angle stiffener” is present, proceed to Part V for that wing.

- 1) On the underside of the wing, along the spar identify and mark the center of the rib flange of the rib at wing station 100.00
- 2) To provide room for installing the strap the strut must be removed at the wing junction. Cradle the wing securely and remove the strut fork connection bolt where it attaches to the main spar.
- 3) Carefully drill out and remove all existing rivets approximately. 8” inboard and 8” outboard of the mark made in step 1.

CAUTION

Do not to enlarge drill holes beyond tolerance or severe spar damage may occur.

- 4) Precisely mark the centre of the stainless steel strap using a felt marker.
- 5) Slide the stainless steel strap under the leading edge wing skins and up against the under wing skin along the spar channel and then center the stainless steel strap on the mark made at step 1. Note that both extremities of the 16” stainless steel strap have been tapered for your convenience. If the strap is set up to tightly against an existing rivet on the underside of the spar cap, the strap is to long and must be shortened. Shorten the strap by grinding it down (a maximum of 0.50 “) in order to relieve stress load on the lower leading edge skin. On occasion, due to the proximity of other rivets, the extremities of the s/s strap may cause undesirable stress on the underside wing leading edge skins. If this occurs, remove rivet(s) in affected area and reinstall using locally fabricated aluminum shims in order to create a more gentle taper at the extremity of the stainless steel strap. (Refer to figure 4 for more details on positioning of the stainless steel strap.)

Air Research Technology Inc.

WingExtension and Spar Reinforcement Installation Guide #18025

Issue # 1 , December 15, 2011

- 6) The stainless steel strap , when properly located will be covered by the leading edge wing skins bit may be visible on the aft edge. When the correct position is established, accurately mark the drill hole positions on the stainless steel strap, the existing L/E wing skin holes can be used as a guide. Then remove the stainless steel strap and proceed to step 8.

NOTE

- **The number of holes to be drilled may vary with different aircraft however (7) rivets on each side of the centre of the strap is the minimum required in order to obtain the desired structural strength at the spar splice.**
- **The hole positions, as marked may not align perfectly down the longitudinal center of your Stainless Steel strap. This is normal because the strut fork may prevent centering; however, a rivet edge distance of 2D or 0.375” must be maintained along the length of the strap.**
- **If 2D edge distance cannot be maintained, contact Air Research Technology for instructions.**

CAUTION

Care must be taken while drilling in order to avoid contact with the strut attach fitting inside the wing. DO NOT SUBSTITUTE the universal head CherryMAX rivets or the Stainless Steel Strap. These parts are shear strength specific and critical to maintaining adequate strength at the wing spar splice. USE ONLY fasteners and materials supplied or referenced herein. If a stainless steel strap is damaged during installation, obtain a new one from the manufacturer.

- 7) Use a drill press and a 3/32” bit, precisely drill out the holes as required.
- 8) Verifying that the holes align precisely along the spar and return to the drill press and enlarge the holes in the stainless steel strap to #10.
- 9) Deburr the stainless steel strap and position it over the leading edge wing skins and up against the underwing skin along the spar channel and center the strap as in Step 5.
- 10) Through the entire thickness of the spar channel including all the skins, use (2) clecos of the correct size and secure the stainless steel strap tightly into position using the holes at each extremity of the strap.
- 11) Using the Stainless Steel strap as a guide, drill through the combined thickness along the spar using #10 drill . Repeat this until all of the holes have been enlarged.

CAUTION

Do not enlarge the drill holes beyond tolerance or severe spar damage may occur.

Air Research Technology Inc.

WingExtension and Spar Reinforcement Installation Guide #18025

Issue # 1 , December 15, 2011

- 12) When all the holes have been drilled to the correct size, remove and deburr the strap. Deburring should be sufficient to only remove the burrs, do not chamfer the rivet holes. Clean out all the metal filings in and around the spar for preparation of final installation.
- 13) Permanently install the Stainless Steel strap using CR3213-6-6 universal head CherryMAX rivets. At the center of the strap, where the wing skins overlap, install (1) rivet CR3213-6-7 universal head CherryMAX rivet. This longer rivet will allow for the additional thickness at the joint due to leading edge skins overlapping at this point as well as the additional thickness of the center rib at this position. DO NOT SUBSTITUTE rivets for any other type.
- 14) Reinstall the strut to the wing, on occasion the tubular structure of the strut may touch one of the heads of the newly installed CherryMAX rivets preventing the strut fork to seat correctly. When this occurs it is permissible to smoothly file out that portion of the tubular strut to clear the rivet head.
- 15) Repeat instruction steps (1 thru 14) for both wings.

INFORMATION CONCERNING DISSIMILAR METAL CORROSION:

(Reference MIL-STD-171)

Stainless Steel 301 1/2 hard (-0.5 V standard galvanic potential)

2024 T3 aluminum alloy at (-0.6 V standard galvanic potential)

Conclusion, the difference in galvanic potential is negligible, there is no risk of dissimilar metal corrosion.

PART V - PLACARDS, DOCUMENTATION FORMS AND REPORTS

- The placards shown in Figure 8 must be installed in full view of the pilot.. Alternatively, the airspeed indicator may be range marked in accordance with Part VII of this document.
- The incorporation of this modification requires completion of a Transport Canada Major Repair or Major Modification Report (STD 571 Appendix L).
- In the U.S.A. Federal Aviation Administration Form 337 must be completed.
- When completing the necessary documentation refer to the STC number.
- Make the necessary installation and certification entries in the aircraft logs.
- Revise the Weight and Balance and aircraft equipment list in accordance with the information listed in Part VI.
- This modification should be released subject to satisfactory test flight confirming that the aircraft flies wings level.

PART VI - W & B INFORMATION

Item	Weight (lbs)	Arm (in)	Moment (lb.in)
<i>WingExtensions</i> LH + RH	16.0	52.0	832
Doublers Packers Angle Stiffeners	1.0	36.0	36
Stainless Straps (If required)	1.0	36.0	36

PART VII – AIRSPEED INDICATOR RANGE MARKING

NOTE

THIS SECTION APPLIES TO Cessna series 182 and 185 all models.

For all Cessna series 185 all models with the *Wing Extensions* installed Vne is reduced to 165 KIAS (189 Mph). On these models the airspeed indicator must be marked with a radial red line at 157 KIAS.

For all Cessna series 182 all models with the *WingExtensions* installed Vne is reduced to 157 KIAS (180 Mph). On these models the airspeed indicator must be marked with a radial red line at 157 KIAS.

Mark airspeed indicator as follows:

- 1) Place a red radial line 0.05” wide by 0.30” long at the appropriate Vne limit as determined by the aircraft series above.
- 2) Red line should preferably be placed on the instrument face by an appropriately rated instrument shop.
- 3) If red line is placed on the cover glass of the instrument, the line must extend onto the instrument bezel so that correct alignment of the cover glass with the face of the dial is maintained, and any rotation of the cover glass is apparent.

Figures

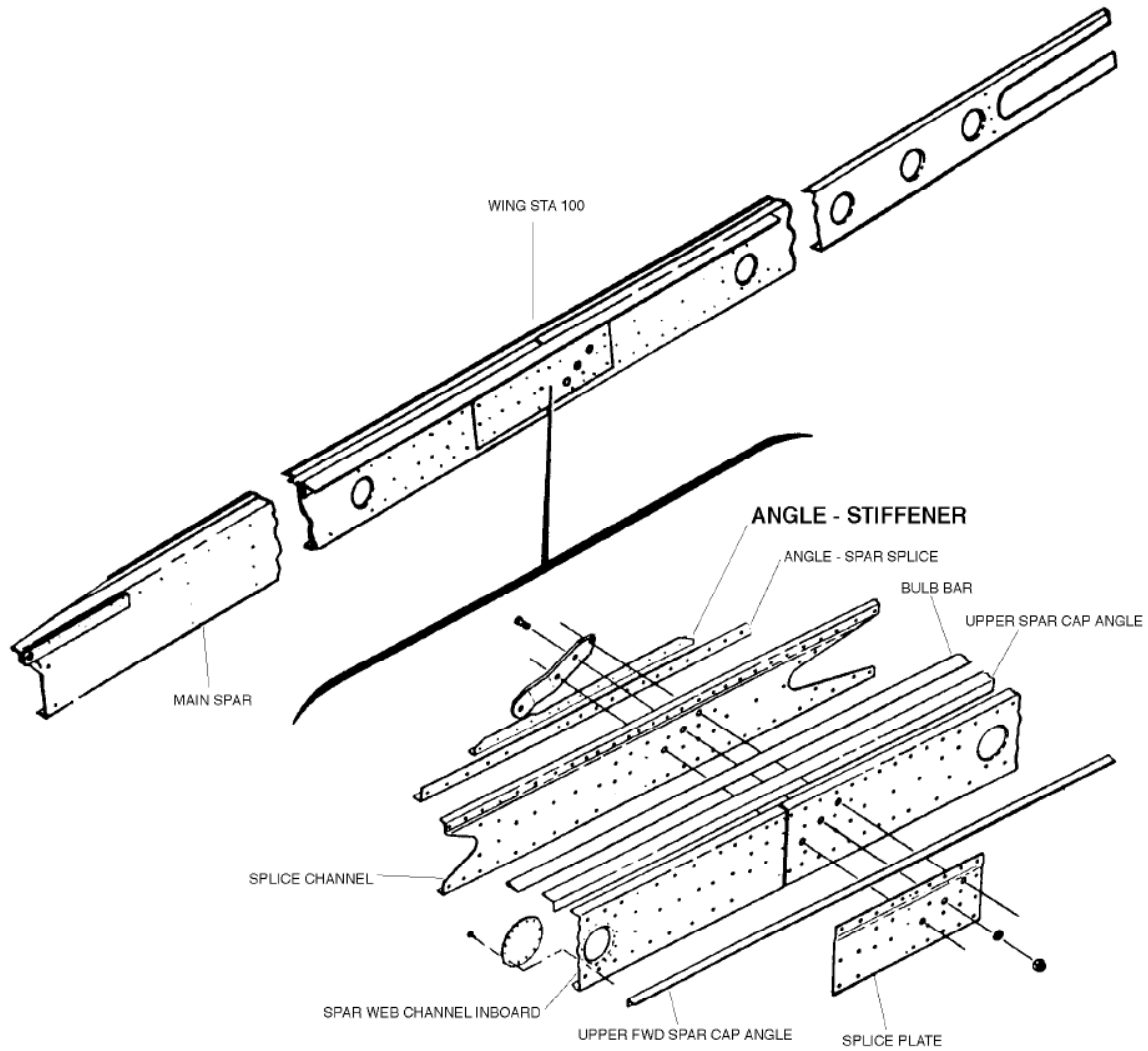

Figure 1: Spar Construction Detail

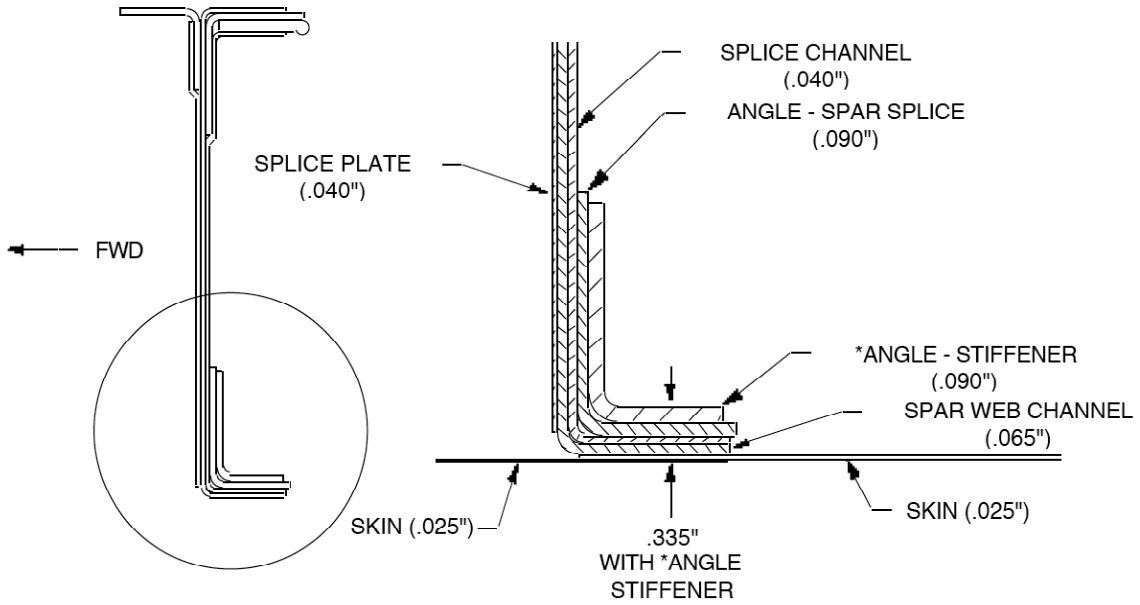

Figure 2: Spar Section Detail With Angle Stiffener Present

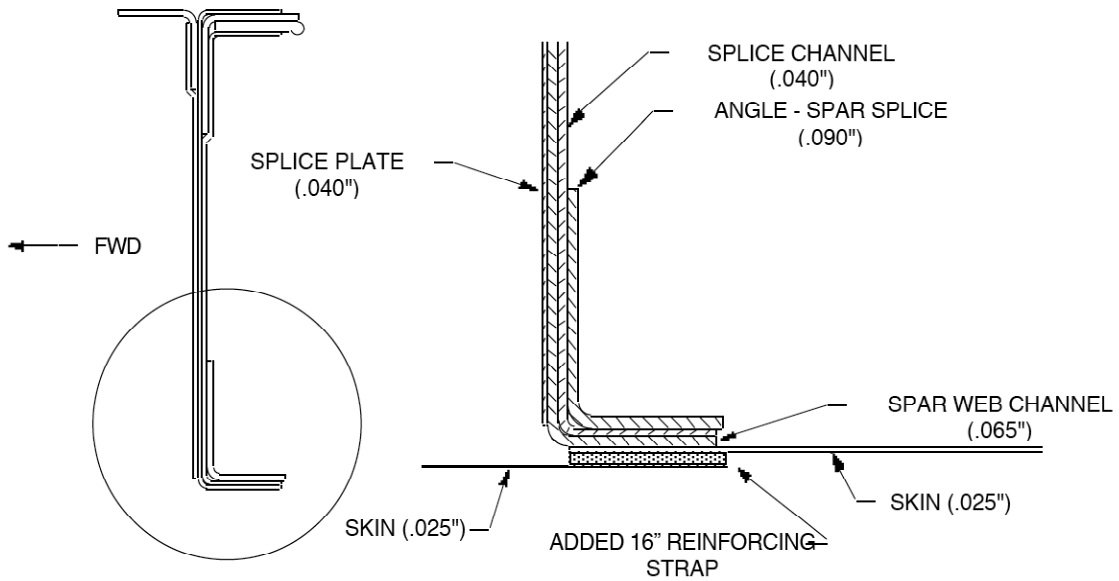

Figure 3: Spar Section Detail Without Angle Stiffener Present

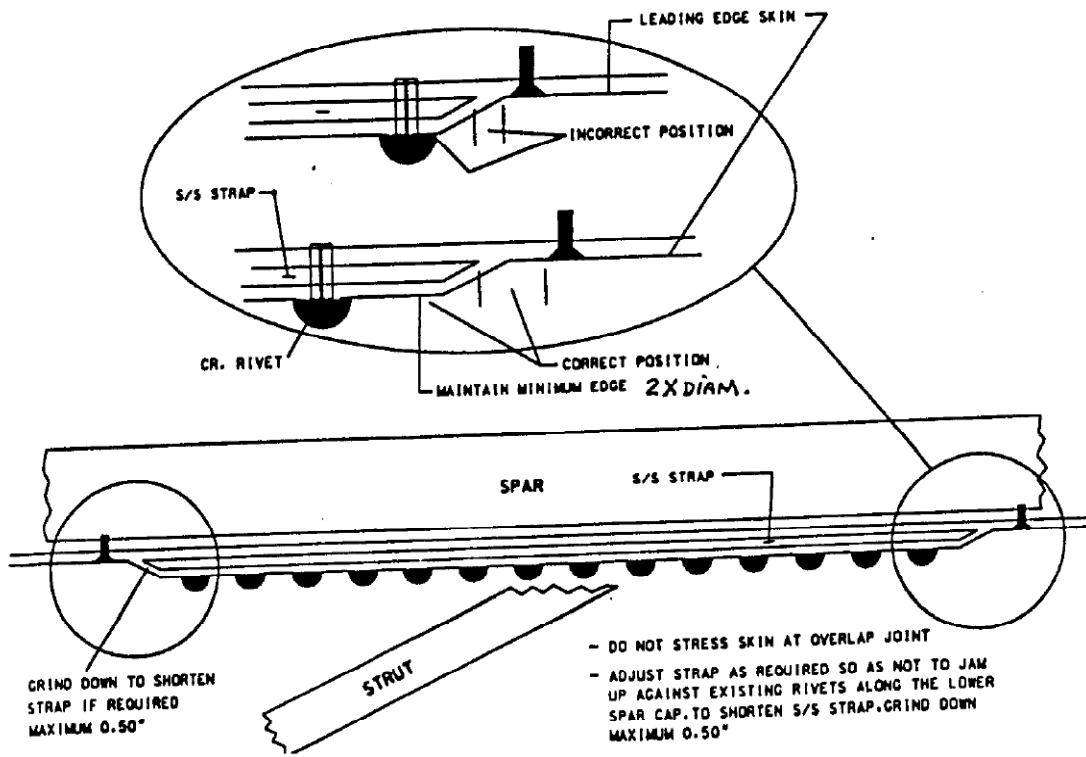

Figure 4: Positioning of Stainless Steel Strap Between Rivets

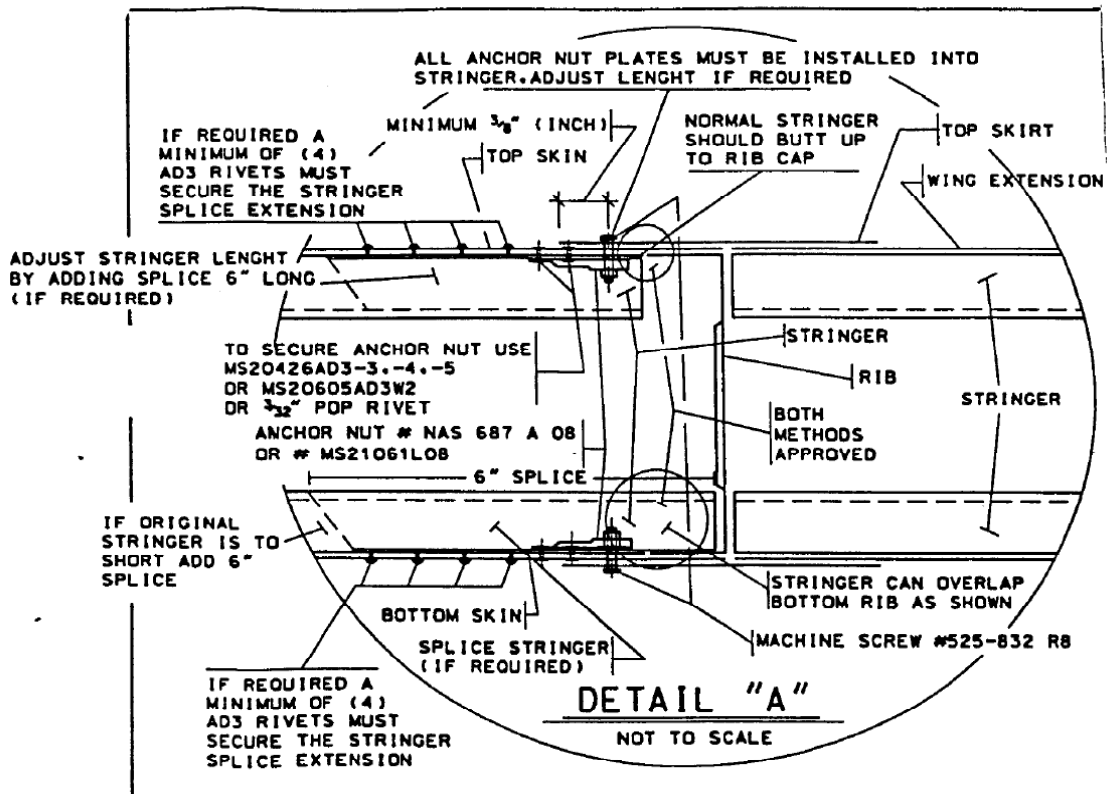

Figure 5: Positioning Anchor Nuts and Splicing Stringers

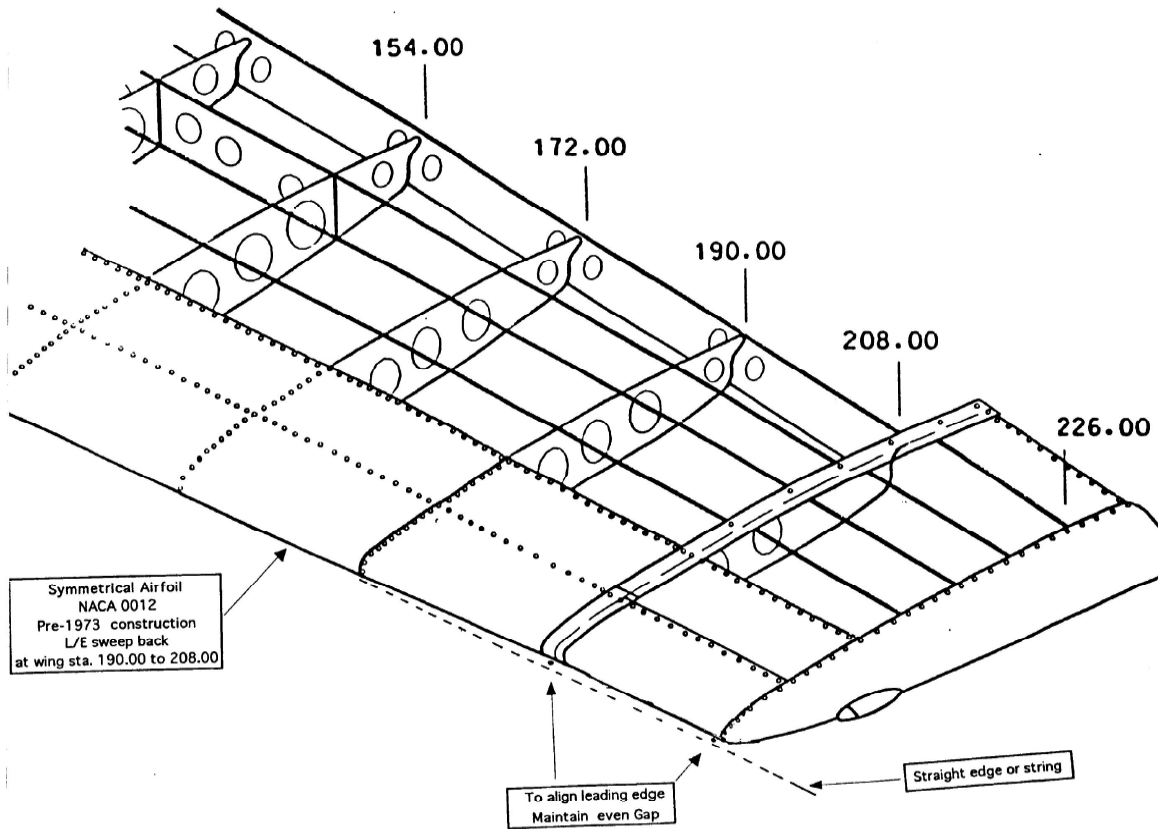

Figure 6: Leading Edge alignment on pre-1973 wings

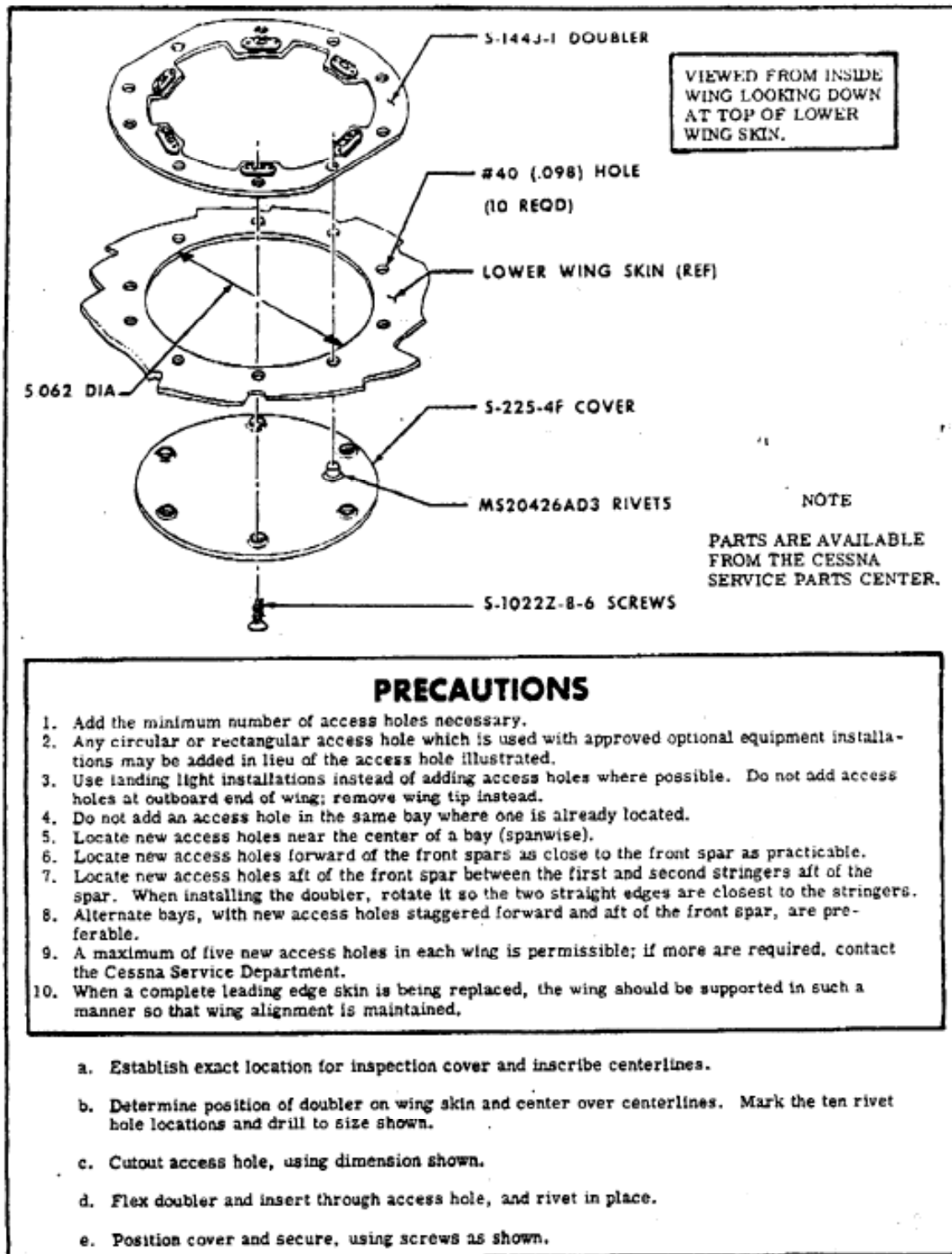
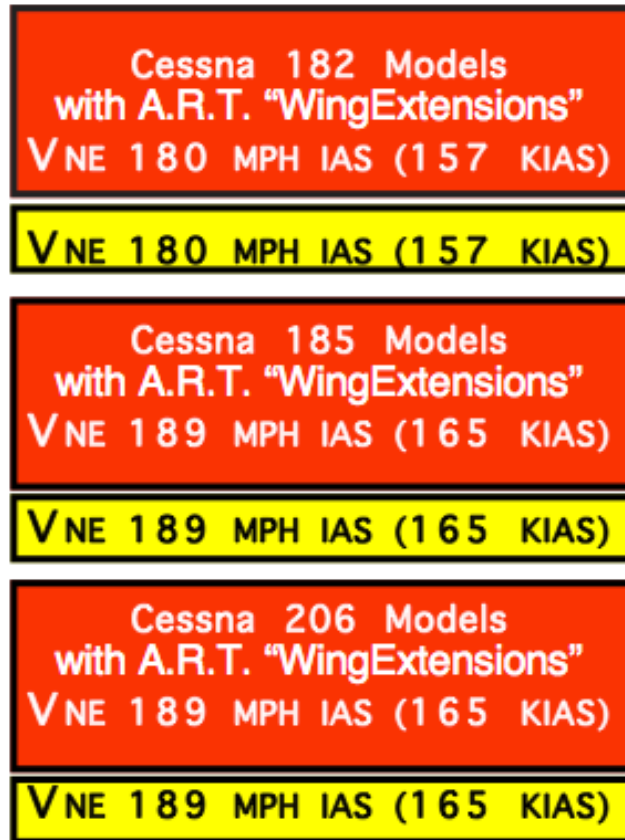

Figure 7: Access Hole Installation



CAUTION
DECAL NOT REQUIRED FOR C-180
USE VNE DECAL APPROPRIATE TO
CESSNA MODEL EQUIPPED WITH
Air Research Technology Inc.
" WingExtensions "

(VNE) Never Exceed Speed decals ART# DEC1582

Figure 8: Placards